

PL3 SERIES

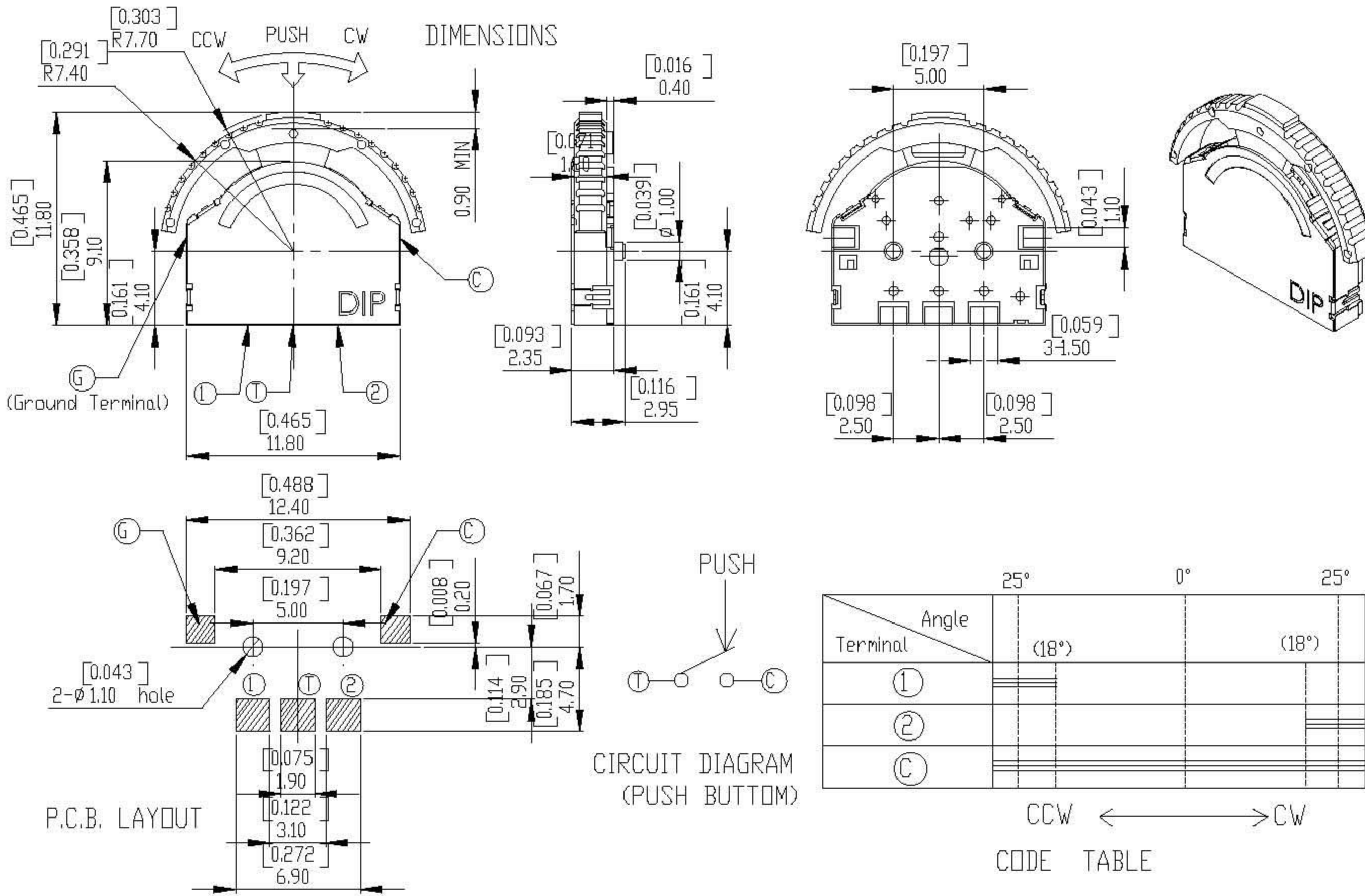

DIMENSIONS

PL3-AC-V



General Tolerance: ±0.2mm

HOW TO ORDER

PL 3 - □ C - V - □

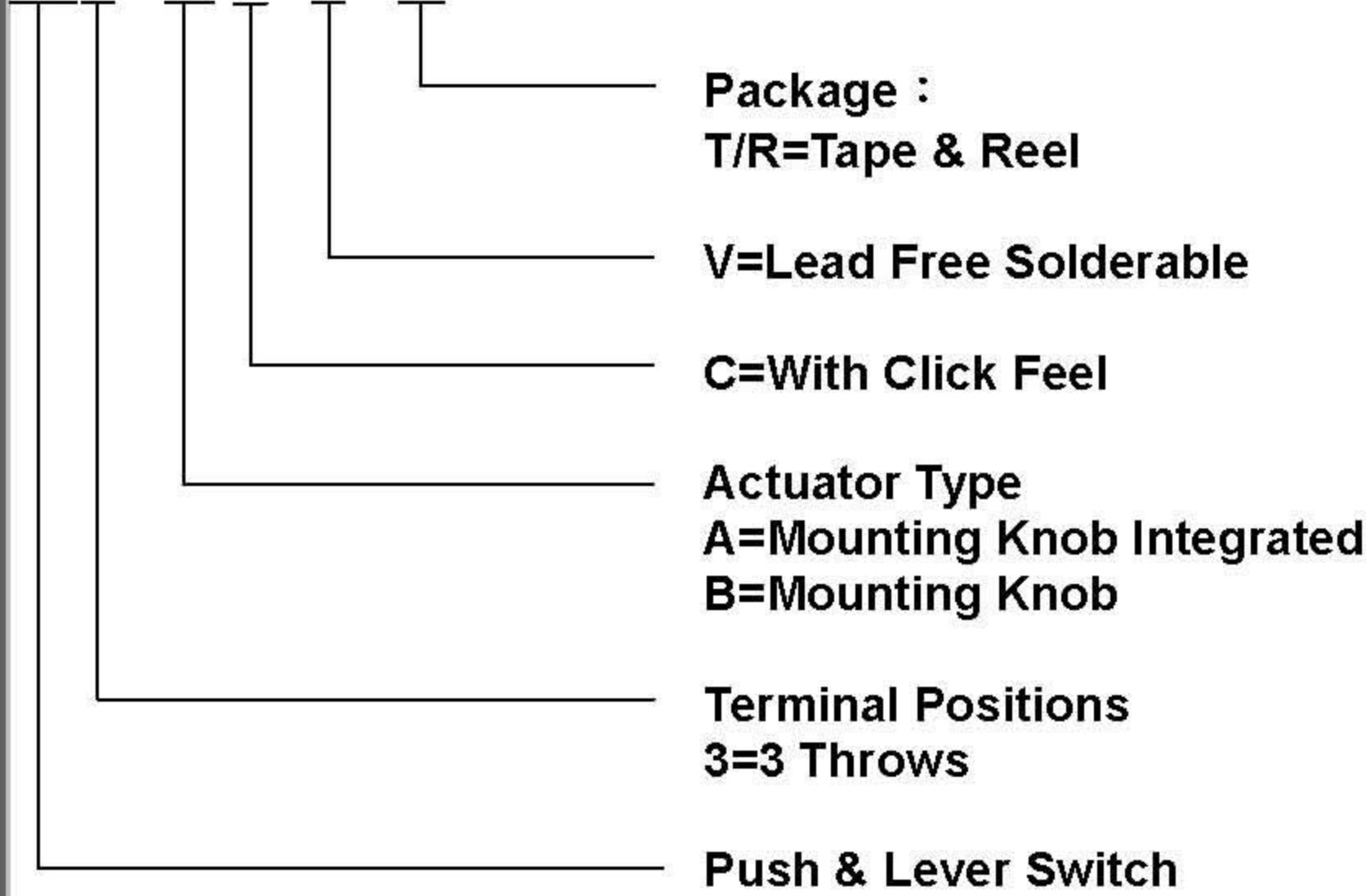

SPECIFICATION

△MECHANICAL

Operation Force: Center push $200\pm 100\text{gf}$.

Lever{CW.CCW} $70\pm 50\text{gf}$

Operation Temperature Range: -10°C to $+60^{\circ}\text{C}$

Storage Temperature Range: -30°C to 80°C

Mechanical Life: 100,000 cycles.

△ELECTRICAL

Electrical Life: 100,000 cycles

Rating: 1mA , 5VDC

Contact Resistance: 500Ω max.

Insulation Resistance: $100\text{M}\Omega$ min. 100V DC

Dielectric Strength: 100VAC / 1 minute

Circuit: Single pole single throw.

MATERIAL

△Cover : Stainless steel.

△BASE : UL940V-0 Nylon High-Temp Thermoplastic.

Color : Black

△STEM : UL940V-0 Nylon High-Temp Thermoplastic.

Color : Black

△CONTACT : Phosphor bronze with silver cladding at Contact surface.

△TERMINAL : Phosphor bronze with silver cladding at Contact surface.

△SPRING : Stainless steel.

SOLDERING PROCESS

△HAND SOLDERING: Use a soldering iron of 30 watts, controlled at 350°C approximately Max 5 seconds while applying.

△Temperature Profile :

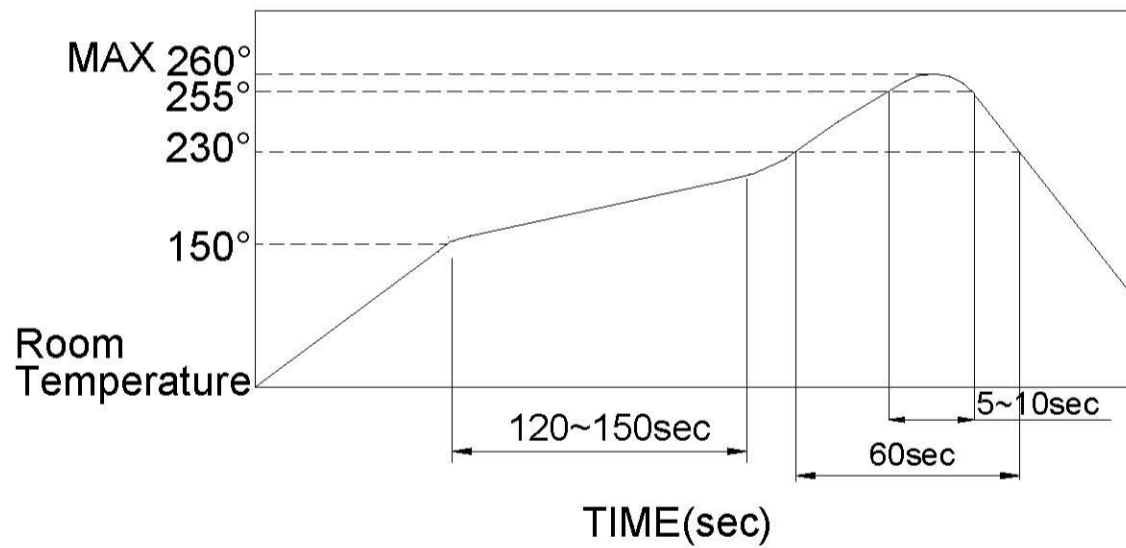

PACKING

Part Number	Number Per Reel
PL3-A	900

PL3-A REEL

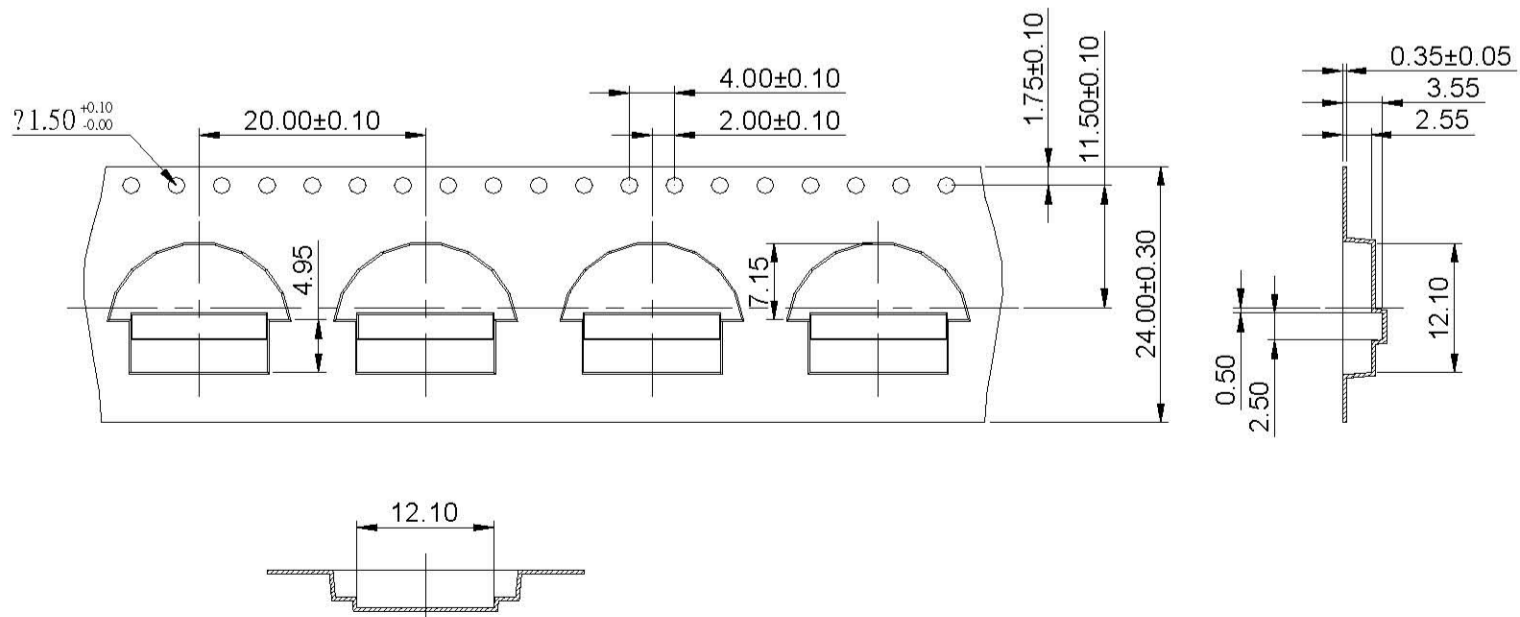

General Tolerance : $\pm 0.1\text{mm}$